

SP2 316L Stainless Steel Tactile Strip

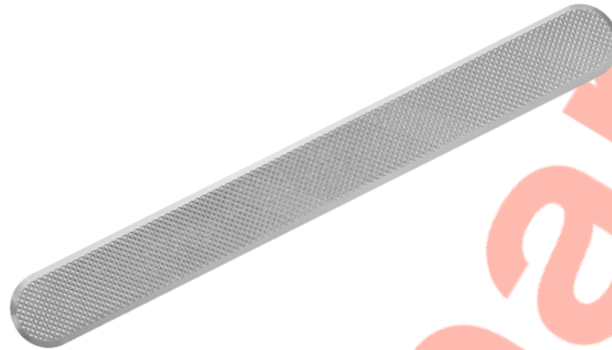

Above. Shown with machined finish

Description

Manufactured from 316L Stainless Steel.

Pyramid textured surface for increased stability in slippery environments.

Machined polish finish as standard.

Constructed from non corrosive material.

Long Service life.

To be installed onto finished surfaces.

Dimensions

B1: 20mm B2: 15mm H: 6mm L:400mm

M6 x 15mm welded pin

M6 x 12mm machined pin

Size Options

Lengths ranging from 280mm - 500mm

Material Options:

Brass - 316L S/S - Bronze - Aluminium

Fixing Pin Options

Self adhesive - Welded pin - Machined pin - No pin

Full installation service - POA

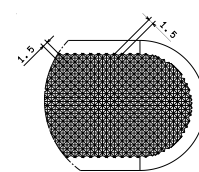
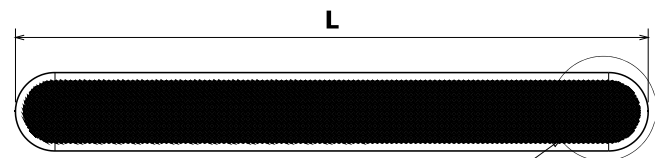
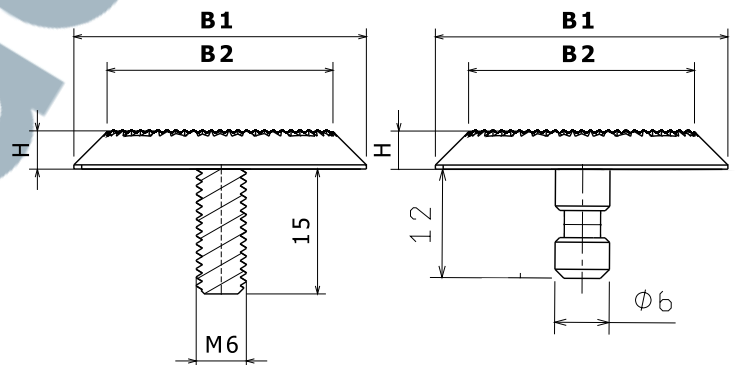

SP2 316L Stainless Steel Tactile Strip

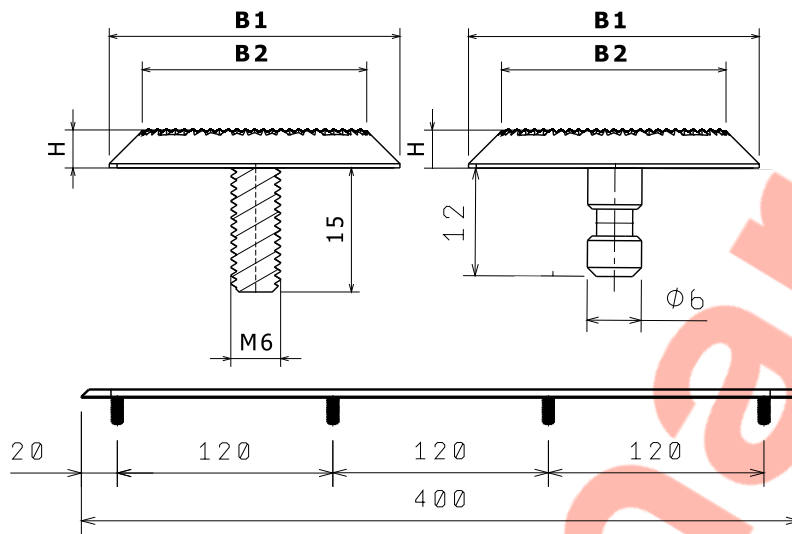

Installation Welded Pin

1. Drill holes 7mm dia x 16mm depth.
2. Remove dust and debris caused by drilling.
3. Following the product guidelines, screw the nozzle on, and press the trigger - the two part resin will mix in the nozzle. Pour a sufficient amount to fill the drilled hole.
4. Push the stud into the hole firmly ensuring an edge seal around the entire stud
5. Allow a few minutes for the Polymer Modified Adhesive to set.

Installation Machined Pin

1. Drill holes 7mm dia x 13mm depth.
2. Remove dust and debris caused by drilling.
3. Following the product guidelines, screw the nozzle on, and press the trigger - the two part resin will mix in the nozzle. Pour a sufficient amount to fill the drilled hole.
4. Push the stud into the hole firmly ensuring an edge seal around the entire stud
5. Allow a few minutes for the Polymer Modified Adhesive to set.

Installation Self Adhesive

1. Prep area where stud is to be situated by using a grease and dirt remover, i.e white spirits. Then let dry thoroughly.
2. Once area is dried, peel backing to stud off and press down firmly.

Note: We highly recommend only using the self-adhesive studs on tiled floors.

For layout suggestions please refer to the below.

<https://www.studmarc.com/knowledge-base/how-far-apart-should-tactile-studs-be-installed-from-each-other/>