

# DATASHEET

## AT Aluminium Tactile Demarcation Stud, 25mm

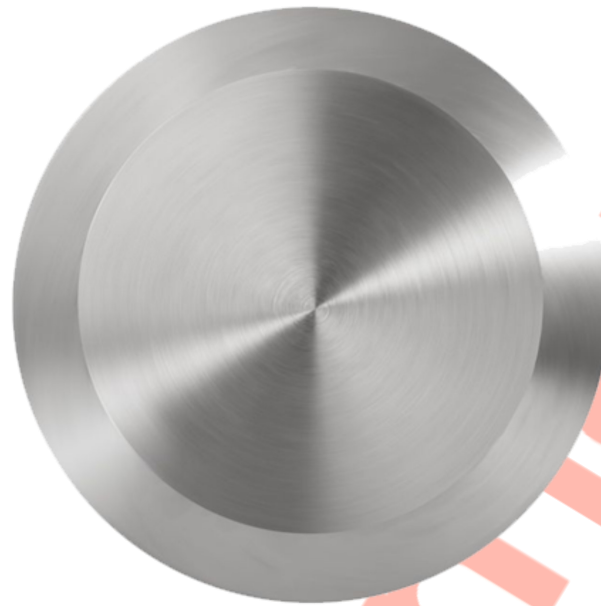

**Above.** Shown with machined finish

### Description

Manufactured from Aluminium.

Machined polish finish as standard.

Constructed from non corrosive material. Long Service life.

To be installed onto finished surfaces.

### Dimensions

D1: 25mm $\varnothing$

D2: 15mm $\varnothing$  x 5mm thick top

M6 x 15mm welded pin

M6 x 12mm machined pin

### Options

Diameter options: 15 - 100mm

Fixing pin length options - 12 - 80mm

### Material Options:

Brass - 316L S/S - Bronze - 304 S/S

### Fixing Pin Options

Self adhesive - Welded pin - Machined pin - No pin

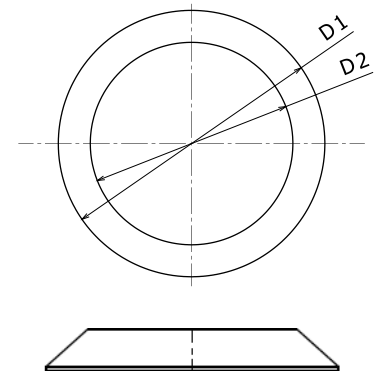

**Full installation service - POA**



## AT Aluminium Stud Installation

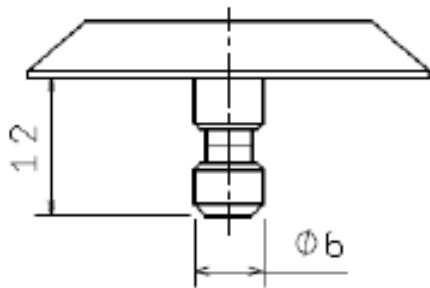

### **Installation Machined Pin**

1. Drill holes 7mm dia x 13mm depth.
2. Remove dust and debris caused by drilling.
3. Following the product guidelines, screw the nozzle on, and press the trigger - the two part resin will mix in the nozzle. Pour a sufficient amount to fill the drilled hole.
4. Push the stud into the hole firmly ensuring an edge seal around the entire stud
5. Allow a few minutes for the Polymer Modified Adhesive to set.

### **Installation Self Adhesive**

1. Prep area where stud is to be situated by using a grease and dirt remover, i.e white spirits. Then let dry thoroughly.
2. Once area is dried, peel backing to stud off and press down firmly.

Note: We highly recommend only using the self-adhesive studs on tiled floors.

### **For layout suggestions please refer to the below.**

<https://www.studmarc.com/knowledge-base/how-far-apart-should-tactile-studs-be-installed-from-each-other/>