

DATASHEET

BT1 Bronze Tactile Demarcation Stud, 25mm



Above. Shown with machined finish

Description

Manufactured from Bronze.

Machined polish finish as standard.

Constructed from non corrosive material.

Long Service life.

To be installed onto finished surfaces.

Dimensions

D1: 25mm \varnothing x 5mm thick top

M6 x 12mm machined pin

Options

Bespoke Diameter options: 15 - 100mm

Bespoke fixing pin length options: 12 - 80mm

Material Options:

Aluminium - 316 S/S - Brass - 304 S/S

Fixing Pin Options

Self adhesive - Machined pin - No pin

Full installation service - POA

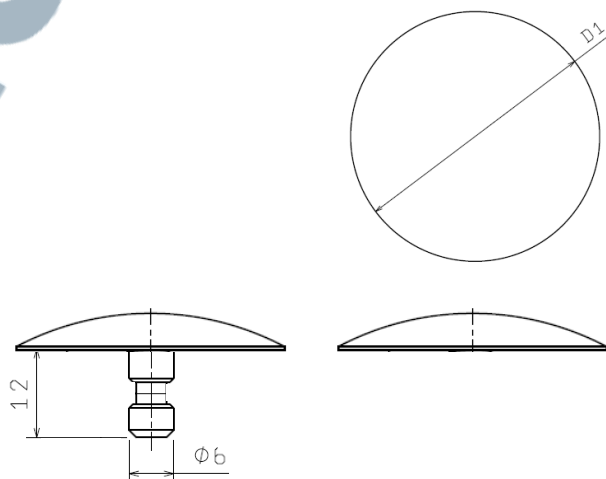

BT1 Bronze Stud Installation

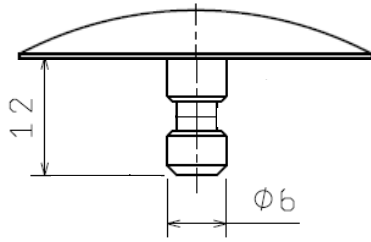

Installation Machined Pin

1. Drill holes 7mm dia x 13mm depth.
2. Remove dust and debris caused by drilling.
3. Following the product guidelines, screw the nozzle on, and press the trigger - the two part resin will mix in the nozzle. Pour a sufficient amount to fill the drilled hole.
4. Push the stud into the hole firmly ensuring an edge seal around the entire stud
5. Allow a few minutes for the Polymer Modified Adhesive to set.

Installation Self Adhesive

1. Prep area where stud is to be situated by using a grease and dirt remover, i.e white spirits. Then let dry thoroughly.
2. Once area is dried, peel backing to stud off and press down firmly.

Note: We highly recommend only using the self-adhesive studs on tiled floors.

For layout suggestions please refer to the below.

<https://www.studmarc.com/knowledge-base/how-far-apart-should-tactile-studs-be-installed-from-each-other/>